



BR150-1 Go-Kart Set Up Instructions

Removal from crate



1. Remove cardboard carton.

Hardware and parts



Headrest



Rear shock



Wheel covers



Gas tank

Rear wheels



Front wheels



Steering wheel



Steering wheel bolt cover



Hardware and parts

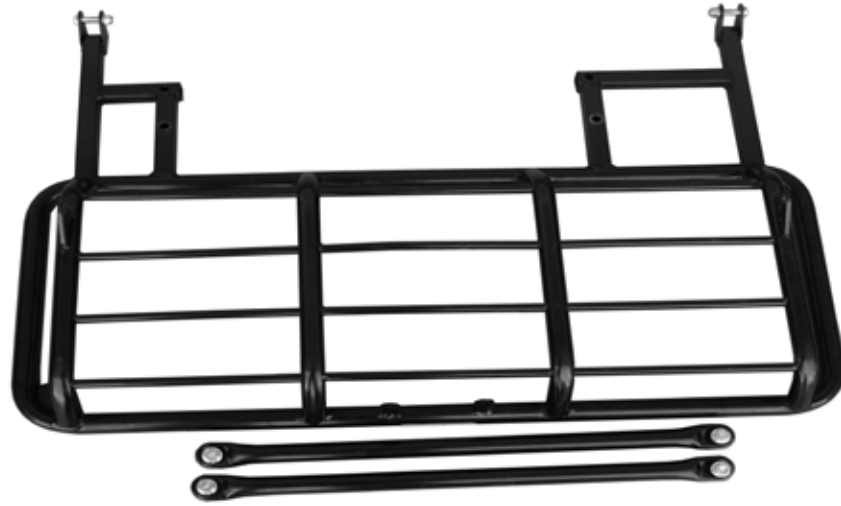

Rear luggage carrier

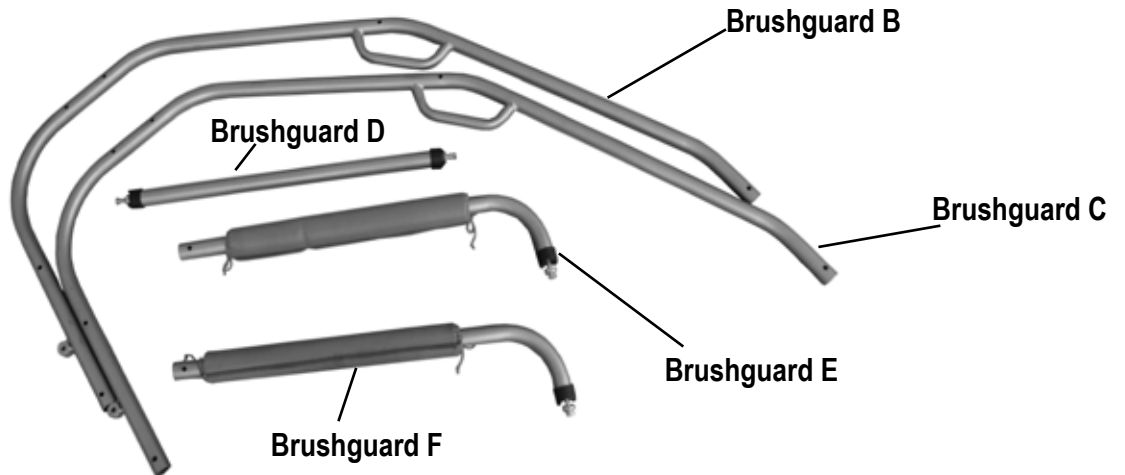
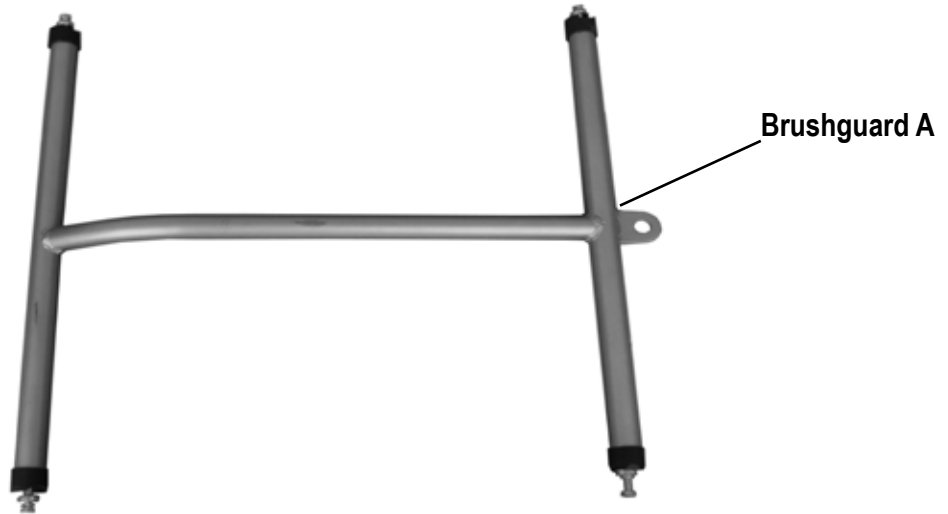

Steering Wheel assembly

2. Loosen 8mm bolts on steering shaft bracket and align steering shaft. Once steering shaft is aligned, torque bolts to 17 ft.lbs.

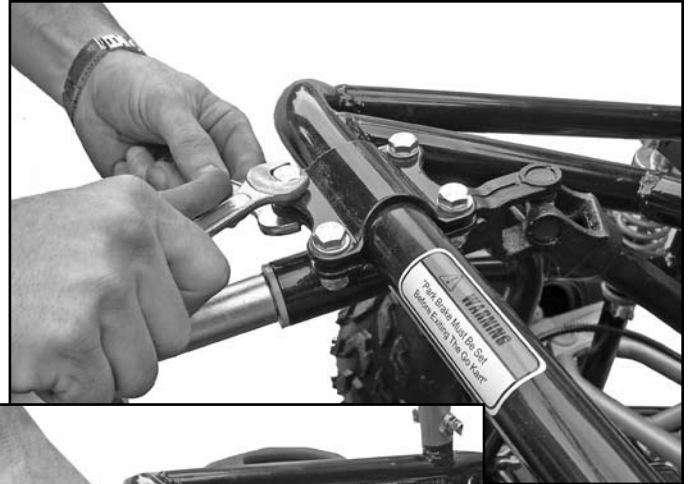

Align



3. Install steering wheel making sure large opening is at top when steering is at center position. Attach steering wheel with 6mm bolts. Torque bolts to 8 ft.lbs. Attach bolt cover to steering wheel, cover will snap in place.

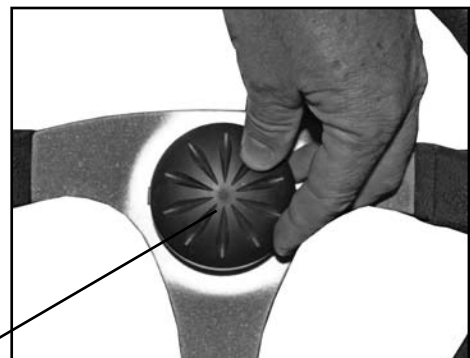

Steering wheel
bolt cover

Front shock absorber attachment

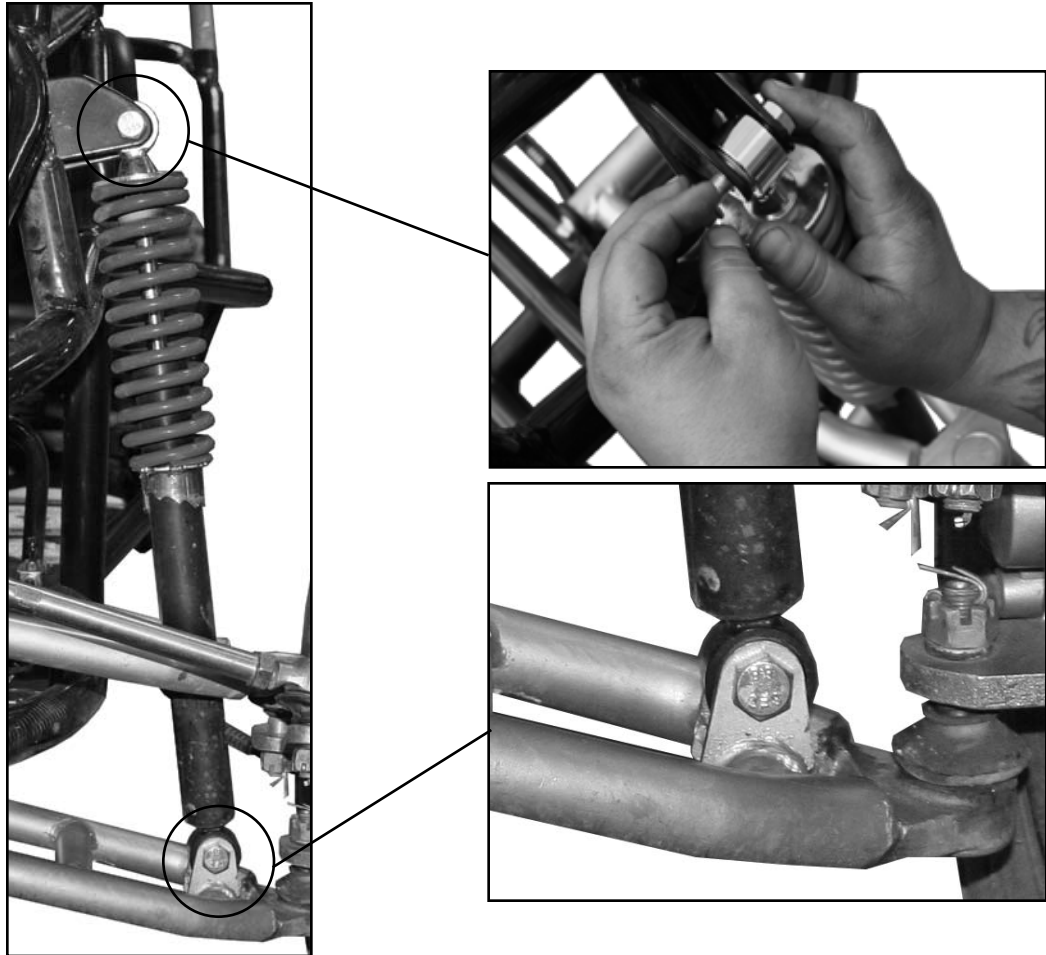

4. Attach both front shock absorbers to top brackets on frame and lower a-arm using M10X45 bolts and M10 nuts with 33ft.lbs. of torque.

A-arm attachment

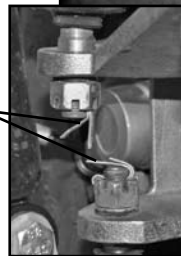

Cotter pin

5. Attach upper and lower a-arms to left and right spindles using M12 nuts with 35ft.lbs of torque. Secure nut with cotter pin.

Tie-rod attachment



6. Attach left and right tie-rod ends to left and right spindles using M10 nuts with 35ft.lbs. of torque. Secure nut with cotter pin.



Cotter pin

Rear shock absorber attachment

Rear stabilizer bar



7. Remove rear stabilizer bar and throw away. Stabilizer bar is for shipping purposes only. NOTE: There is only ONE stabilizer bar.

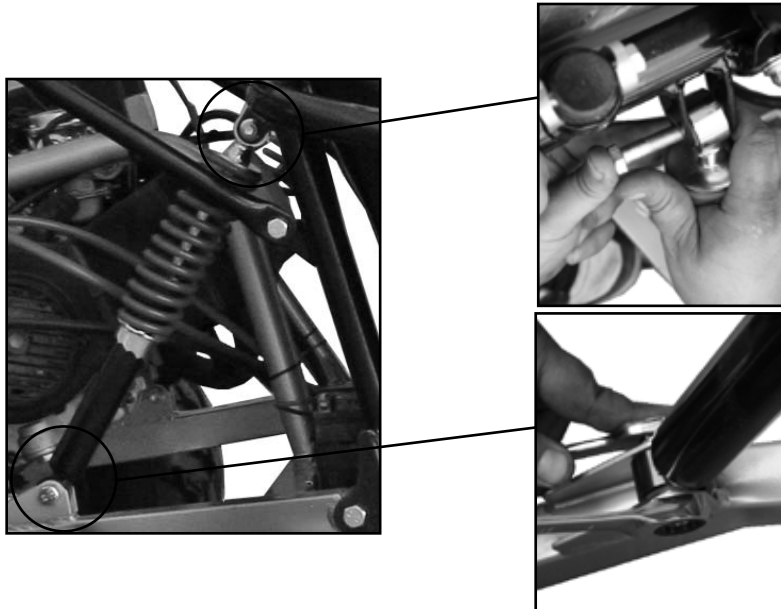

8. Attach rear shock absorber where stabilizer bar was using M10x43 bolt and M10 nut on top bracket and M10x45 bolt and M10 nut on bottom bracket with 33ft.lbs. of torque on both. NOTE: The other rear shock absorber will already be attached at the bottom. You will need to attach the top of shock to frame.

Headrest and Brushguard installation

9. Attach left and right headrests by inserting bracket in holes on seat back.



Brushguard assembly complete

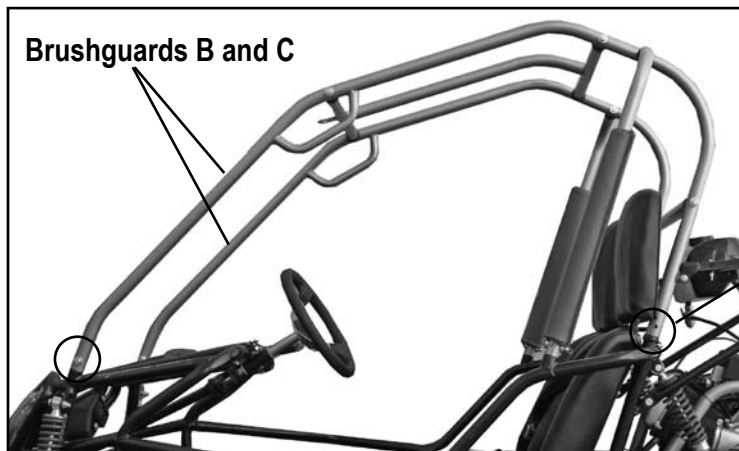

10. Attach brushguards B and C using M8x58 bolts and M8 nuts with 17ft.lbs. of torque.

Brushguard A

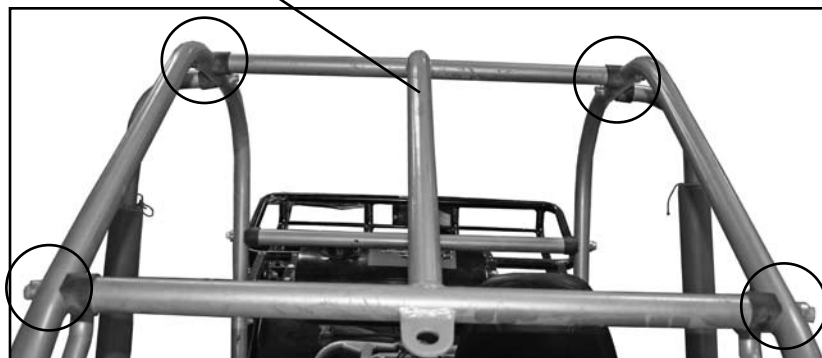

11. Attach brushguard A to Brushguards B and C using M8x58 bolts and M8 nuts with 17ft.lbs. of torque.

Brushguard installation



12. Attach brushguard D to Brushguards B and C behind seats using M8x58 bolts and M8 nuts with 17ft.lbs. of torque.

Make sure the brushguard pad and cover are attach to brushguards E and F.



Note: Install bolt with nut on rear side (closest to rear of go-kart) of brushguard.

13. Attach brushguards E and F to brushguard B and C and the frame using M8x58 bolts and M8 nuts with 17ft.lbs. of torque.

Wheel attachment

Arrow must point forward on all wheels

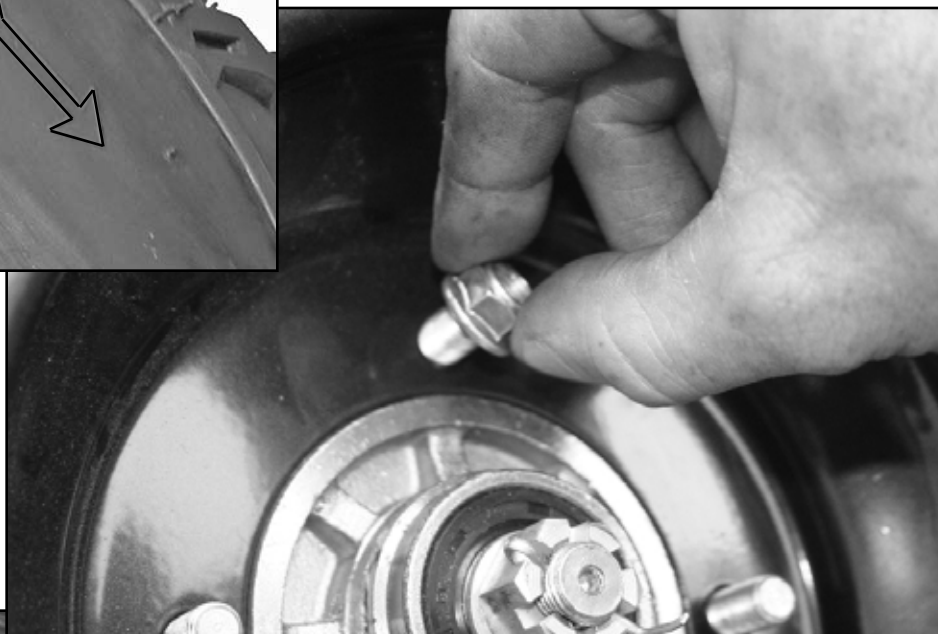
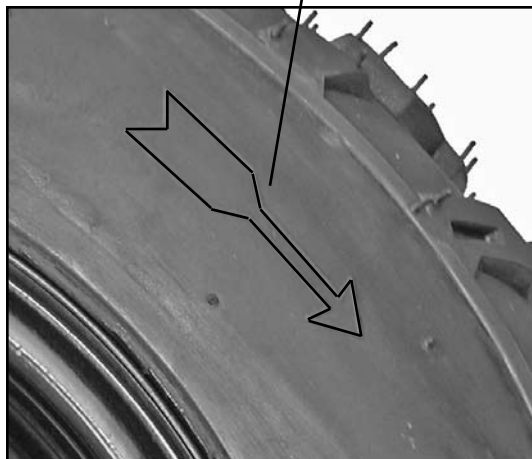

Valve stem

14. Attach all wheels to hubs, large wheels on back of kart and smaller wheels on front, make sure arrow on wheel is pointing forward and valve stem is pointed outward. Torque M10 nuts using 33ft.lbs of torque.

Attaching dust covers



15. Push dust covers over washers in center of the hubs and make sure they are secure.



Attaching rear luggage carrier

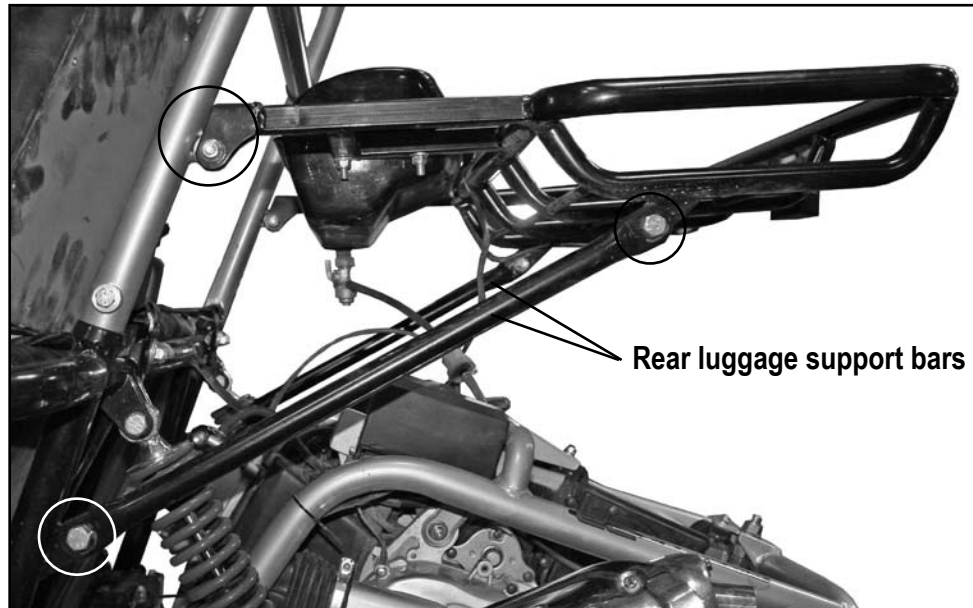

16. Attach rear luggage carrier to frame using M8x51 bolts with 17ft.lbs of torque.



17. Attach luggage support bars to luggage carrier and frame using M8x37 bolts and M8 nuts with 17ftlbs. of torque.

Mounting Tail light

Tail light

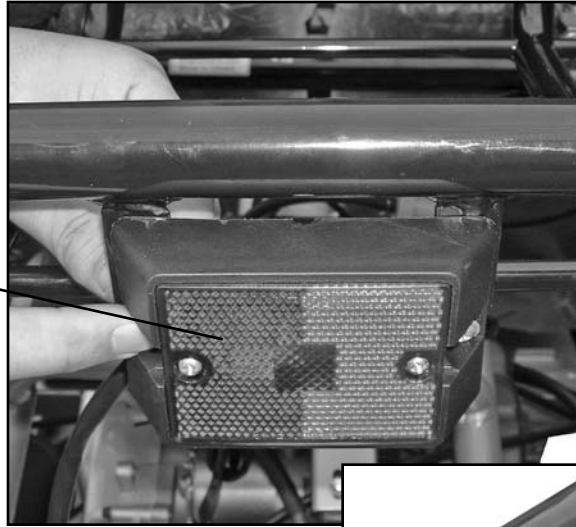

Tail light screw and nut

18. Attach tail light to bracket on rear of luggage rack. Use 6mm Nuts and screws provided.

Luggage rack brackets

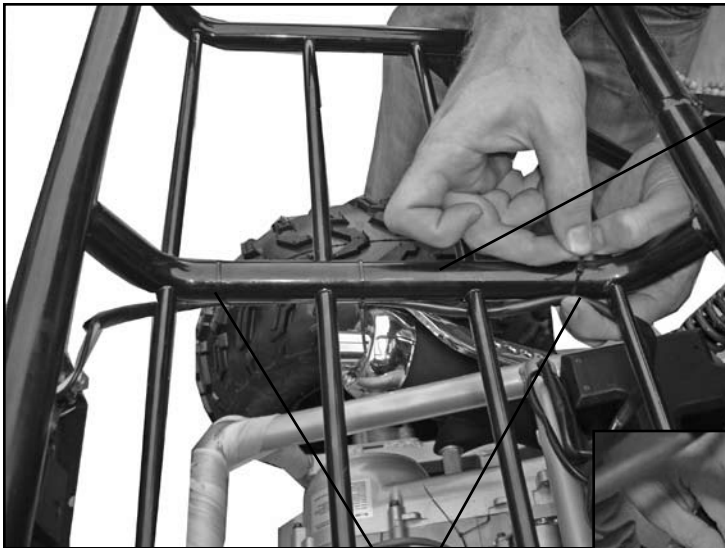
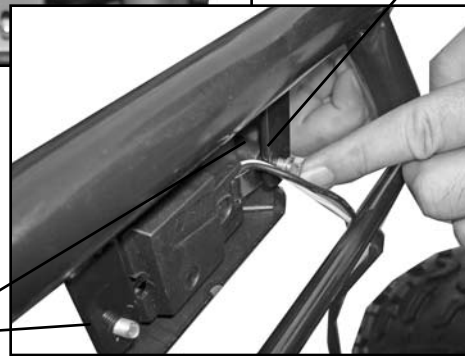

Rack support

19. Route tail light wire down the bottom of middle rack support. "Cable tie" wire to support. Bunch up excess wire and "cable tie" to top of engine mount.

Cable ties

Engine Mount

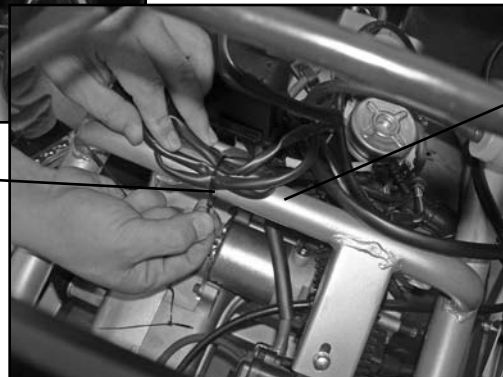

Gas tank installation



20. Bolt fuel tank to top of luggage carrier using M8x47 bolts and M8 nuts with 17ft.lbs. of torque.

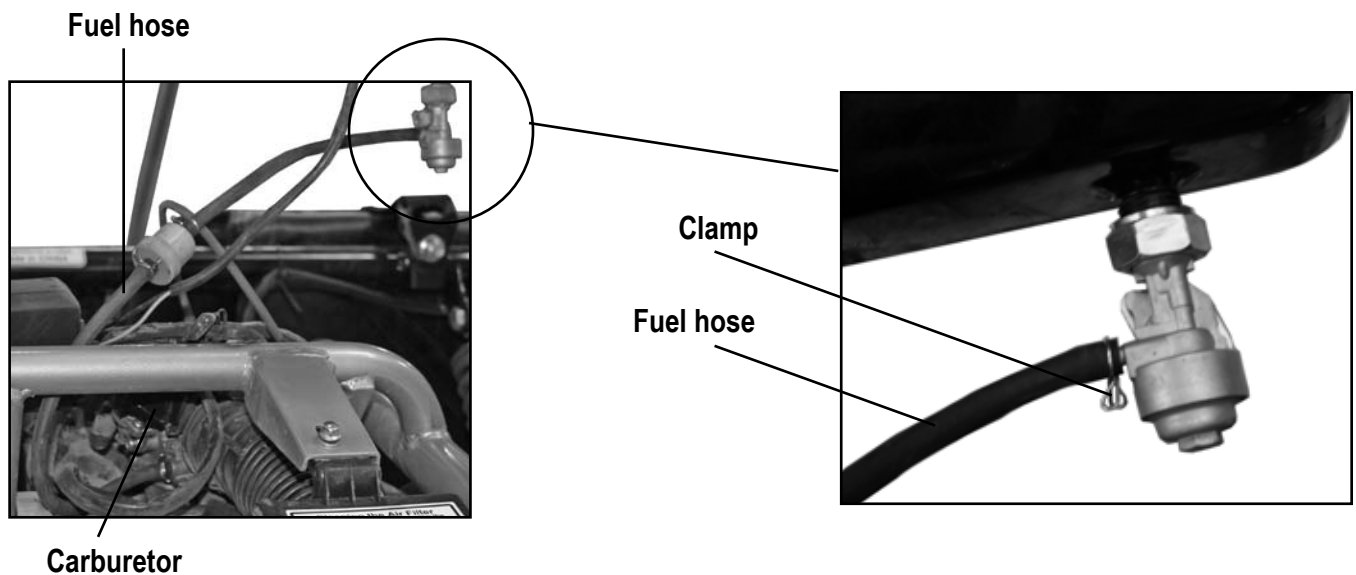

21. Attach fuel hose coming from bottom left of carburetor to fuel valve and secure using provided clamp. With clamp on fuel hose place over nipple on fuel valve, make certain the clamp is secure.

Battery Installation



Eye Protection



Rubber Gloves

▲ WARNING

The following procedure is very dangerous and should be performed with the utmost care and attention. Wear protective eye wear, rubber gloves, and have water available should electrolyte come in contact with skin or eyes. **KEEP ALL CHILDREN AWAY FROM THE AREA WHILE THIS PROCEDURE IS BEING PERFORMED.**

POISON – CAUSES SEVERE BURNS

Contains sulfuric acid.

Avoid contact with skin, eyes, or clothing

To prevent accidents, rinse empty container with water.

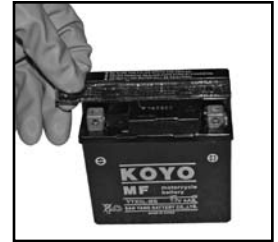

Figure 20



Figure 21



Figure 22



Figure 24



Figure 25



Figure 26

Preparing the battery:

- Place battery on level surface. Remove cap strip from top of battery. (see figure 20)

Wear eye protection and rubber gloves for this step. Once battery strip is removed, locate electrolyte in bottle and place over the six openings. Press firmly down on bottle allowing the battery to pierce the six in-line openings in bottle. Let electrolyte drain into battery until bottle is completely empty. (see figure 21)

- Discard empty electrolyte container in a waste area that is inaccessible to children and animals.

After filling let battery stand for at least 30 minutes before charging. This allows the electrolyte to penetrate plates for optimum performance and ensures longer battery life.

After 30 minutes the battery is ready for its initial charge. Place caps loosely over battery cell holes (see figure 22)

How to Initially Charge the battery:

1. Connect the red positive (+) cable to the red positive (+) pole of the battery. (see figure 24)
2. Connect the black negative (-) cable to the black negative (-) pole of the battery. (see figure 25)

Note: The red positive (+) cable has a larger diameter than the black negative y cable.

3. Charging rate: Charge battery @ 0.7 Amps for 5 ~ 10 hours.
 - After charging is complete, install securely all six battery caps (see figure 26)

Battery Installation

22. Install battery into battery tray located under seat.

23. Once battery is firmly seated in tray, attach red positive (+) wire to positive (+) terminal on battery, then attach black negative (-) wire to negative (-) terminal on battery.

Battery tray

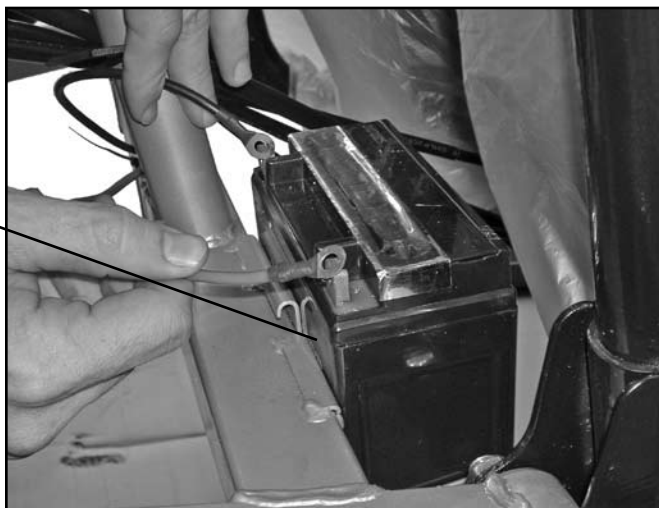

Battery strap

Battery cover

24. Place battery cover over battery. Attach battery strap to hold battery in place.

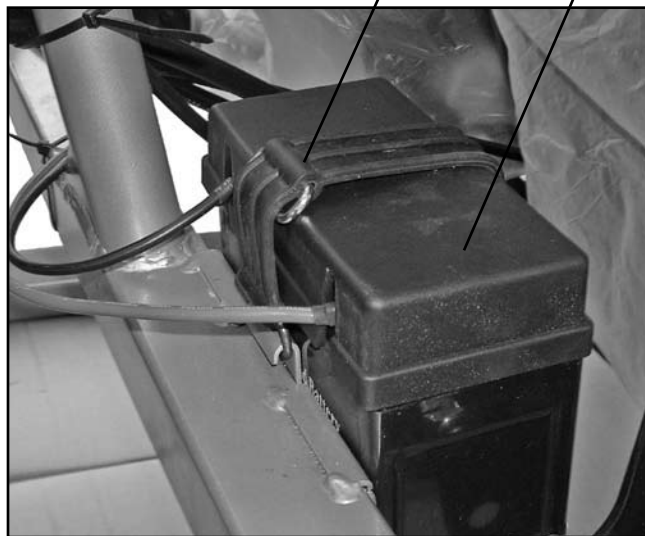

Gas and Oil

25. Fill gas tank as specified in owners manual.



26. Fill engine with correct amount of oil. Refer to owners manual for oil types and quantity.

27. Refer to owners manual for proper starting instructions.

!!WARNING!!

This engine may be shipped with packing oil. This oil should be drained and replaced with new oil as described in the owners manual. Never attempt to start engine without first replacing the engine oil with the proper amount and grade as described in the owners manual.